

Applications.

- 3 Stage Heat Pump.(B512GZ)
- 3 Stage Heat and Cool.(B512GZ)
- Water pump interlock.
- O/A economy cycle (B512GE model)

Features and Benefits.

System switch.

7 Day 4 event time clock.

Time clock Battery backup.

24 Hour countdown timer.

After hours run timer.

Three temperature control modes.

Temperature setback operating mode.

Two operating fan modes.

Single or 3 speed fan control.

Ventilation control.

Zone control.

Display. Time, room or set point.

Dirty filter warning.

Optional remote sensor control.

Temperature set point range limits.

Sensor calibration

Remote stop/start interface.

Adjustable temperature operating parameters.

Adjustable Compressor start delay.

Adjustable Fan run-on for electric heating.

Pump interlock with fault display.

240 or 24vac control systems.

Australian designed and manufactured.

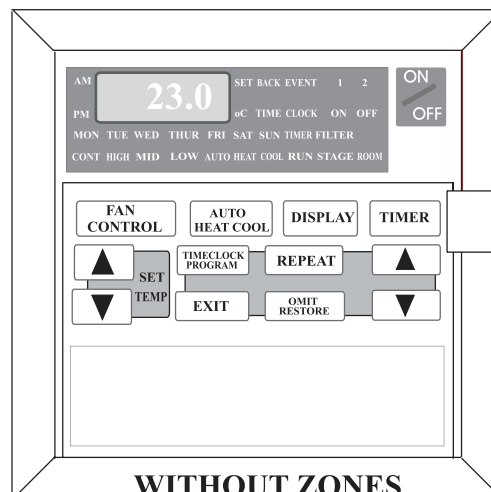
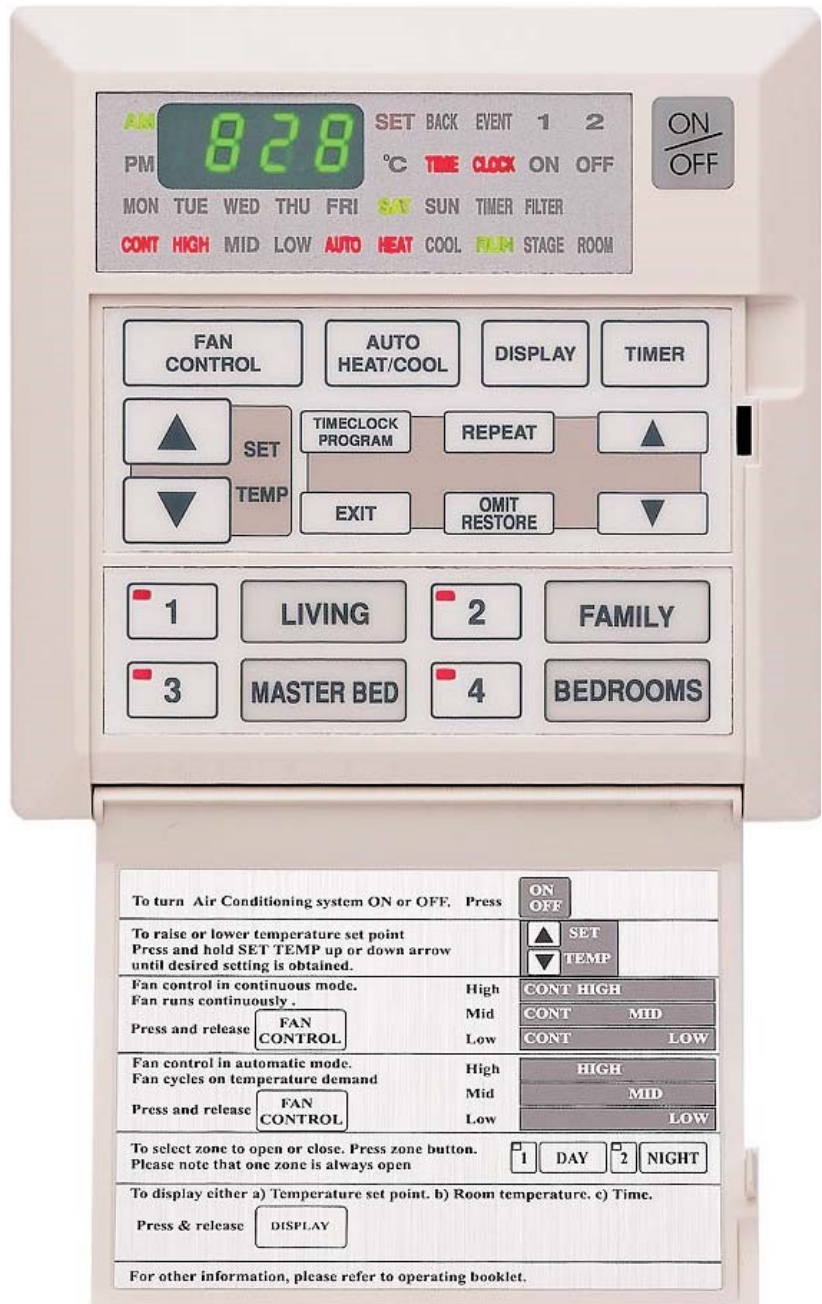

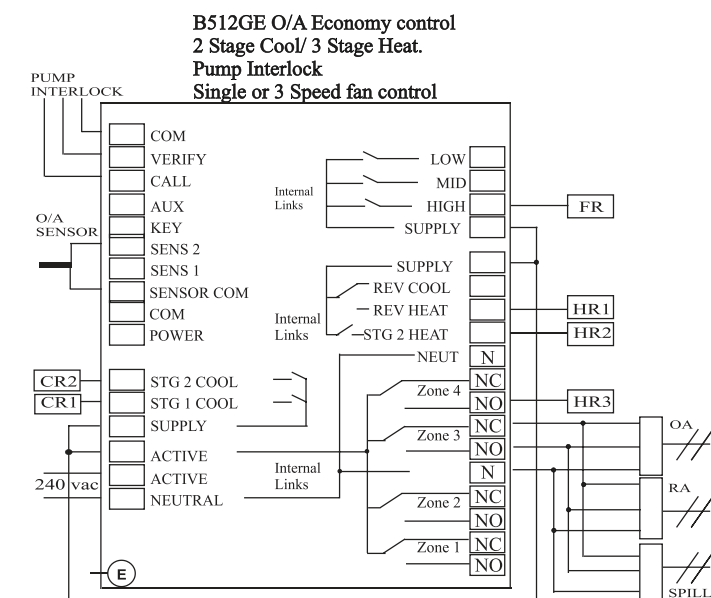
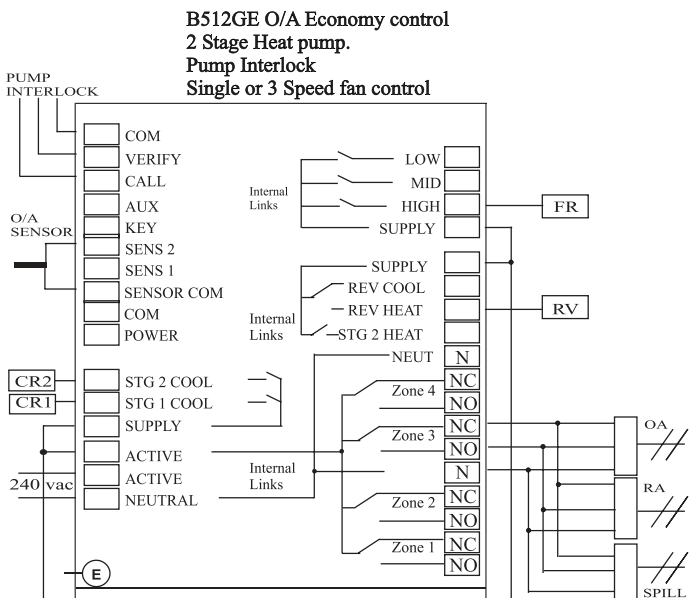
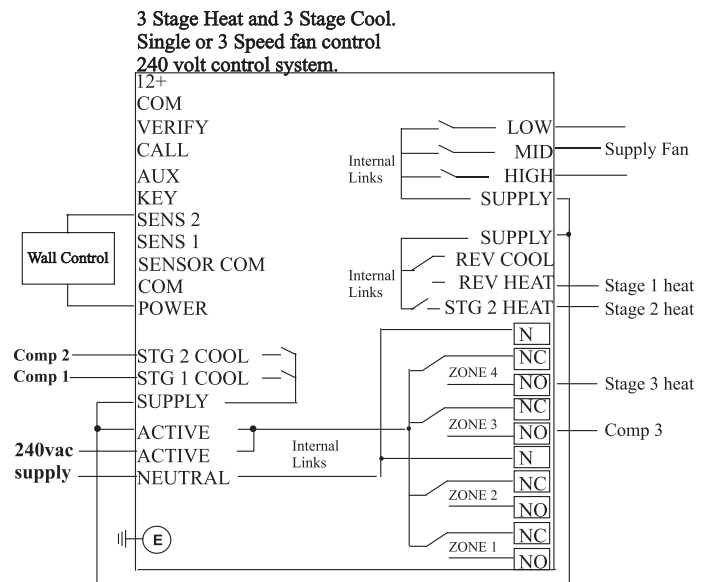
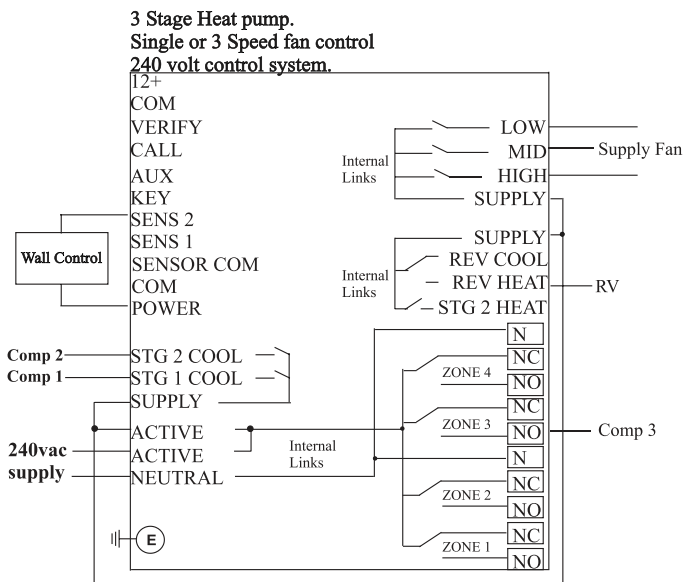
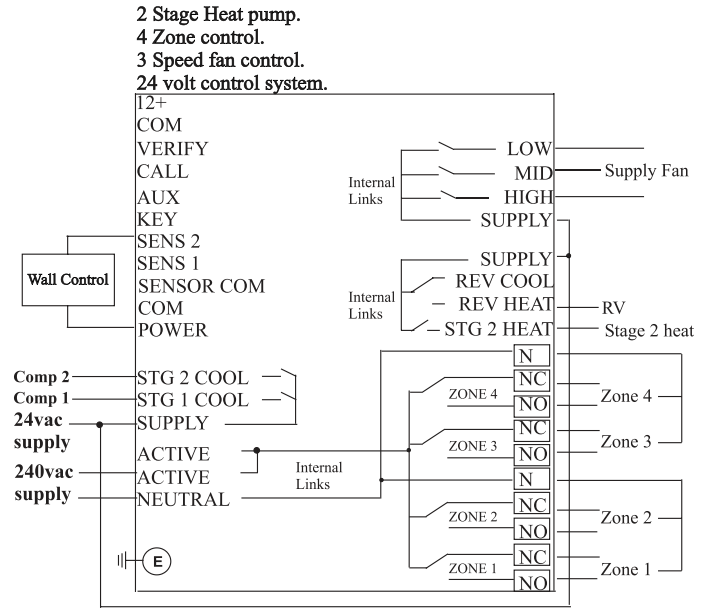
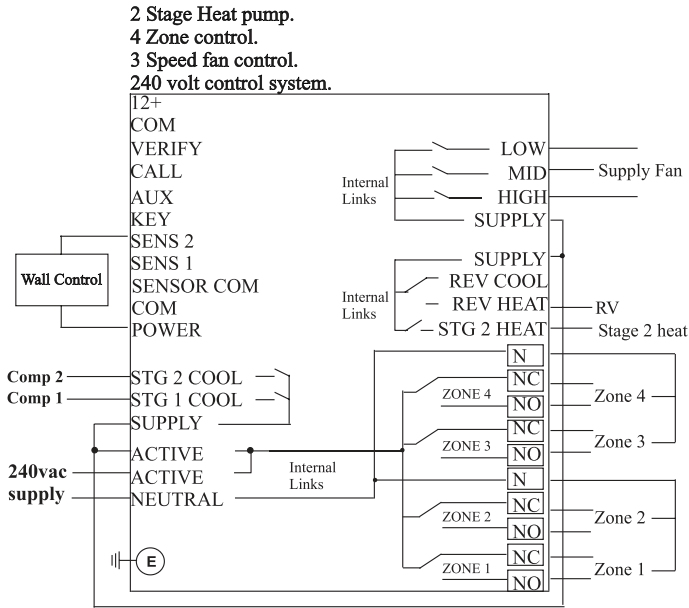

Wall Control and Relay module control wiring connections.

Standard wiring connection.

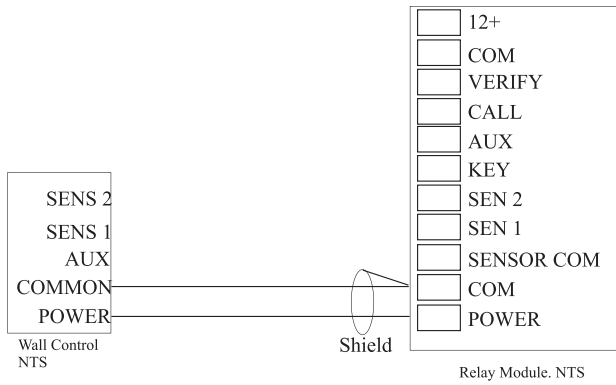

Remote sensor S1.

Wall Control sensor not used. Dip switch 6 to off position.

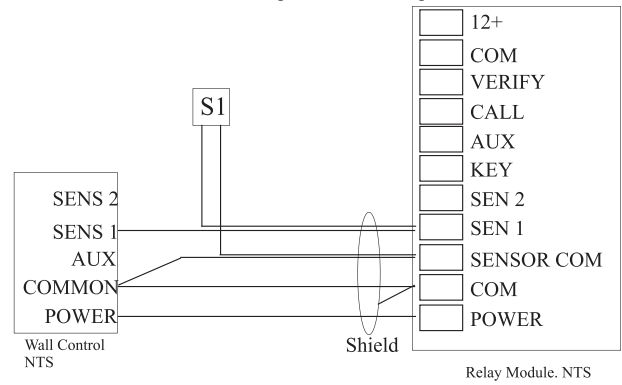

Dual Sensor control. Remote sensor S2 and Wall Control sensor.

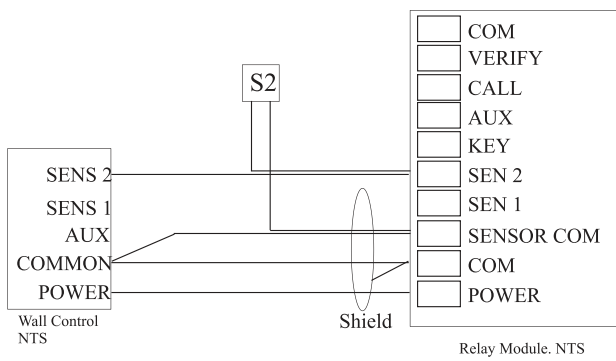

Dual sensor control. Remote sensors S1 and S2.

Wall Control sensor not used. Dip switch 6 to off position

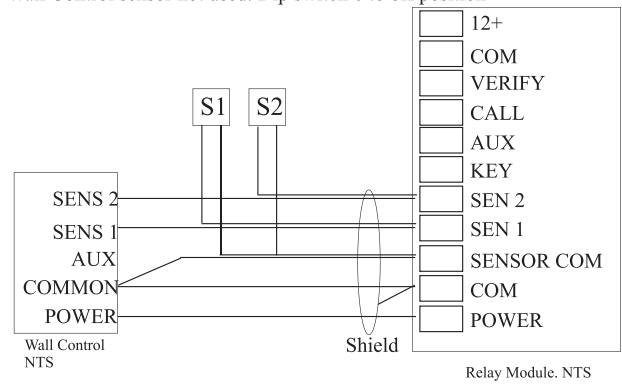

External interface. I.e (Home Automation)

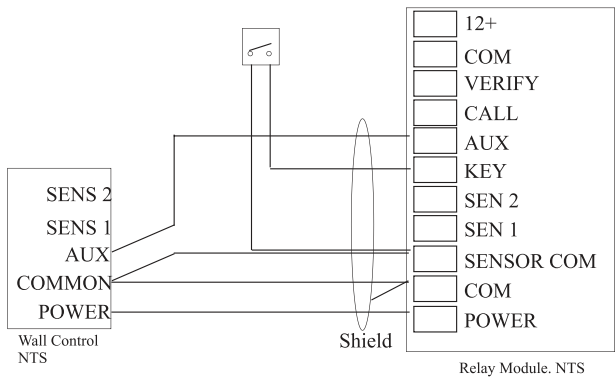

Remote after hours run timer

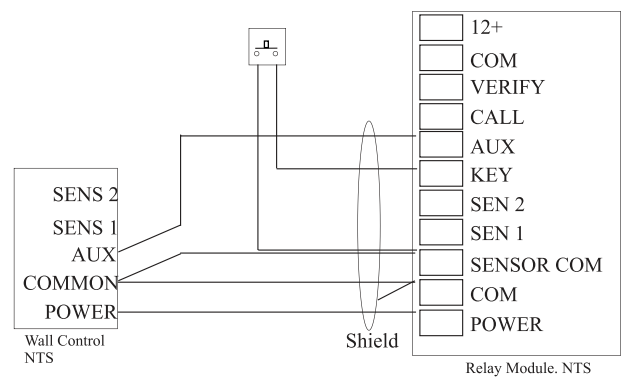

Dual sensor control, external interface and LEASAM condenser pump interlock.

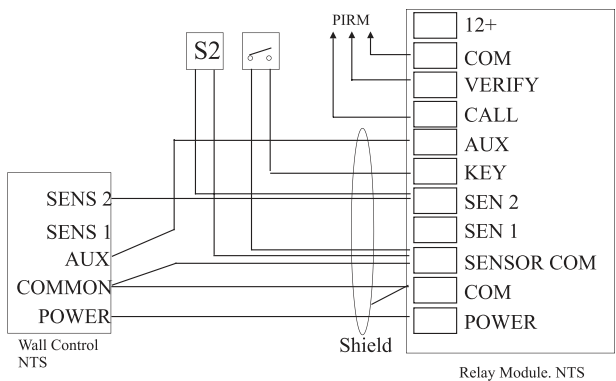

External interface and pump flow verification via Pressure Switch

